

TECHNICAL INFORMATION MANUAL

GMV9/GCV9 40" 90% Gas Furnace Units

Model and manufacturing numbers
listed on page 3.

- Refer to Service Manual RS6300003 Rev. 1 for installation, operation, and troubleshooting information.
- All safety information must be followed as provided in the Service Manual.
- Refer to the appropriate Parts Catalog for part number information.

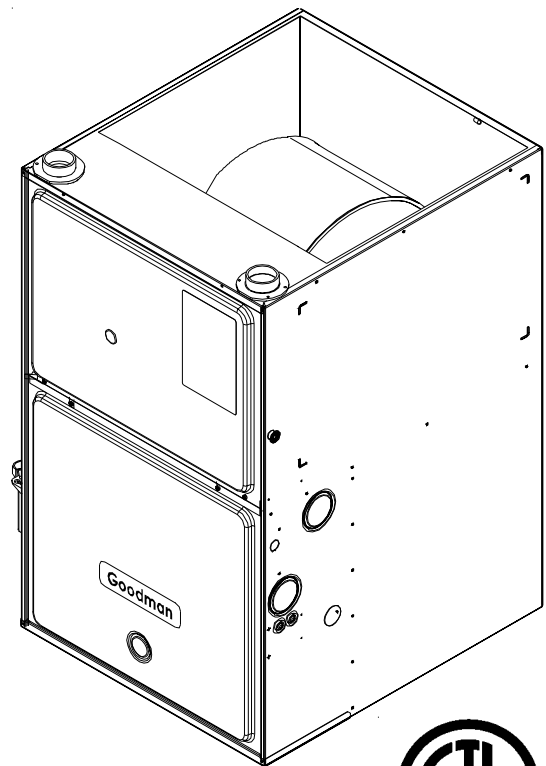
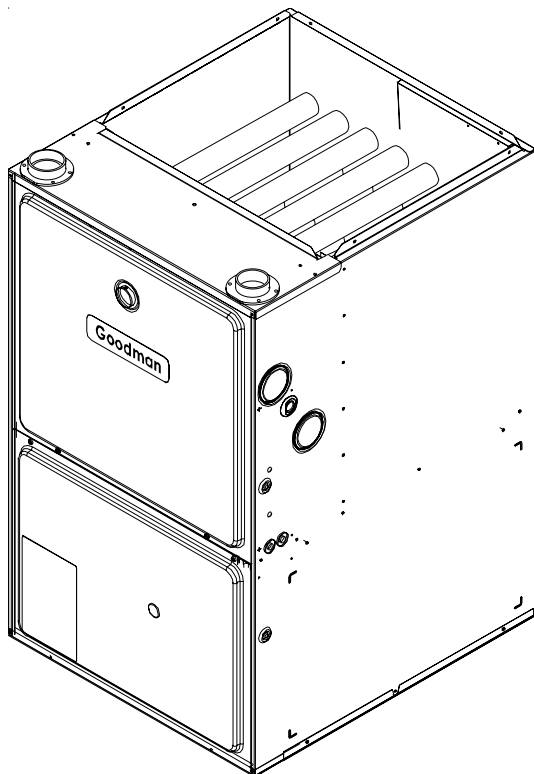

This manual is to be used by qualified HVAC technicians only. Goodman does not assume any responsibility for property damage or personal injury due to improper service procedures performed by an unqualified person.

RT6612011
November 2004

PRODUCT IDENTIFICATION

The model and manufacturing number are used for positive identification of component parts used in manufacturing. Please use these numbers when requesting service or parts information.

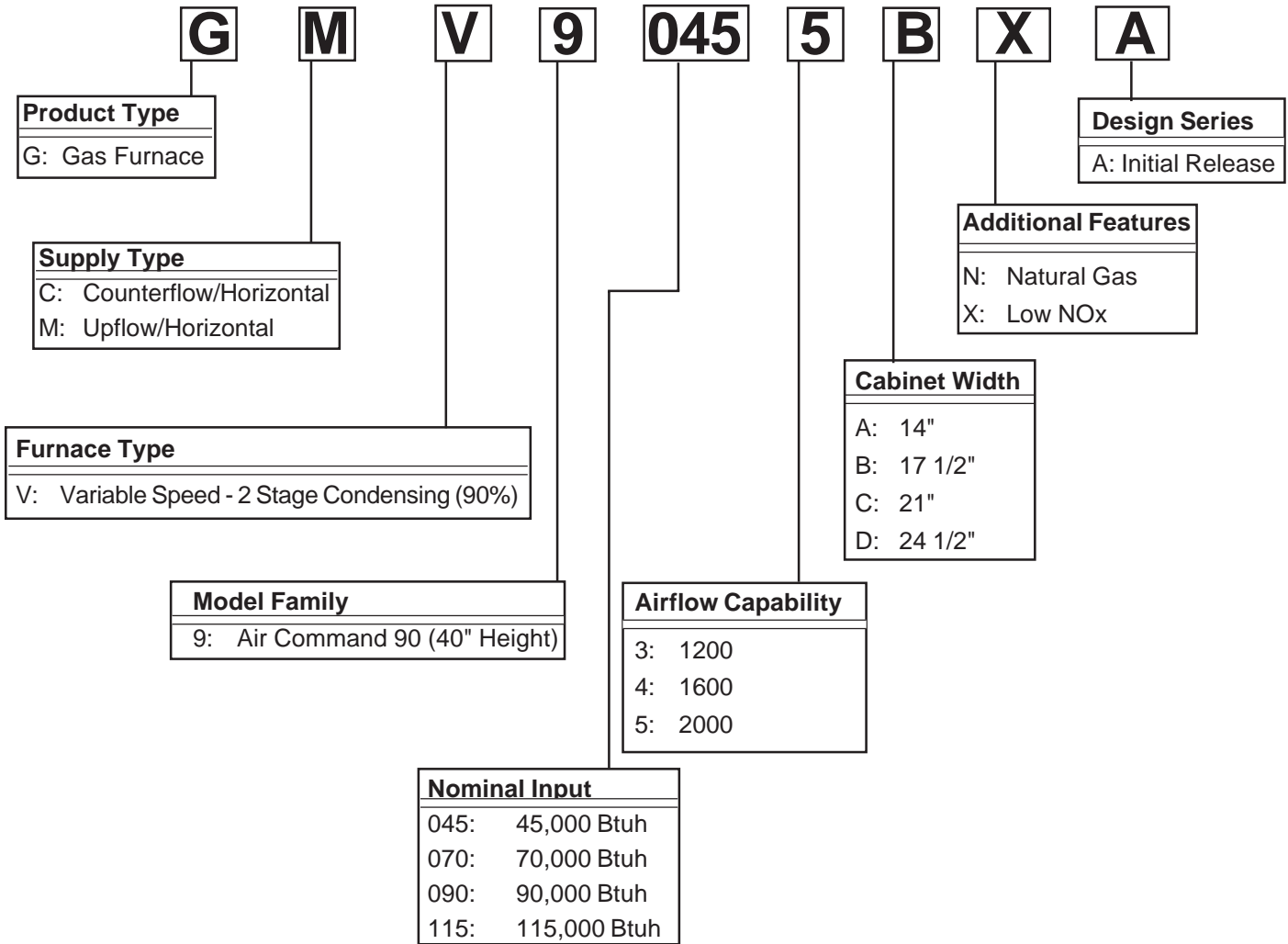

IF REPAIRS ARE ATTEMPTED BY UNQUALIFIED PERSONS, DANGEROUS CONDITIONS (SUCH AS EXPOSURE TO ELECTRICAL SHOCK) MAY RESULT. THIS MAY CAUSE SERIOUS INJURY OR DEATH.



GOODMAN WILL NOT ASSUME RESPONSIBILITY FOR ANY INJURY OR PROPERTY DAMAGE ARISING FROM IMPROPER SERVICE OR SERVICE PROCEDURES. IF YOU PERFORM SERVICE ON YOUR OWN PRODUCT, YOU ASSUME RESPONSIBILITY FOR ANY PERSONAL INJURY OR PROPERTY DAMAGE WHICH MAY RESULT.

PRODUCT IDENTIFICATION

The model and manufacturing number are used for positive identification of component parts used in manufacturing. Please use these numbers when requesting service or parts information.

<u>MODEL</u>	<u>M/N</u>
GMV90704CXA	P1257603F
GMV90905DXA	P1257605F
GMV91155DXA	P1257606F

<u>MODEL</u>	<u>M/N</u>
GCV90704CXA	P1257803F
GCV90905DXA	P1257805F

PRODUCT DESIGN

General Operation

The GMV9 and GCV9 furnaces are equipped with an electronic ignition device to light the burners and an induced draft blower to exhaust combustion products.

An interlock switch prevents furnace operation if the blower door is not in place. Keep the blower access doors in place except for inspection and maintenance.

This furnace is also equipped with a self-diagnosing electronic control module. In the event a furnace component is not operating properly, the control module LED will flash on and off in a factory-programmed sequence, depending on the problem encountered. This light can be viewed through the observation window in the blower access door. Refer to the *Troubleshooting Chart* for further explanation of the LED codes and *Abnormal Operation - Integrated Ignition Control* section in the Service Instructions for an explanation of the possible problem.

The rated heating capacity of the furnace should be greater than or equal to the total heat loss of the area to be heated. The total heat loss should be calculated by an approved method or in accordance with "ASHRAE Guide" or "Manual J-Load Calculations" published by the Air Conditioning Contractors of America.

*Obtain from: American National Standards Institute 1430 Broadway New York, NY 10018

Location Considerations

- The furnace should be as centralized as is practical with respect to the air distribution system.
- Do not install the furnace directly on carpeting, tile, or combustible material other than wood flooring.
- When suspending the furnace from rafters or joists, use 3/8" threaded rod and 2" x 2" x 1/8" angle as shown in the Installation and Service Instructions. The length of the rod will depend on the application and clearance necessary.
- When installed in a residential garage, the furnace must be positioned so the burners and ignition source are located not less than 18 inches (457 mm) above the floor and protected from physical damage by vehicles.

Notes:

1. Installer must supply one or two PVC pipes: one for combustion air (optional) and one for the flue outlet (required). Vent pipe must be either 2" or 3" in diameter, depending upon furnace input, number of elbows, length of run and installation (1 or 2 pipes). The optional Combustion Air Pipe is dependent on installation/code requirements and must be 2" or 3" diameter PVC.
2. Line voltage wiring can enter through the right or left side of the furnace. Low voltage wiring can enter through the right or left side of furnace.
3. Conversion kits for propane gas and high altitude natural and propane gas operation are available. See High Altitude Derate chart for details.

4. Installer must supply the following gas line fittings, depending on which entrance is used:

Left -- Two 90° Elbows, one close nipple, straight pipe

Right -- Straight pipe to reach gas valve.

Accessibility Clearances (Minimum)

GMV9 MINIMUM CLEARANCES TO COMBUSTIBLE MATERIALS (INCHES)						
POSITION*	FRONT	SIDES	REAR	TOP	FLUE	FLOOR
Upflow	3	0	0	1	0	C
Horizontal	3	6	0	6	0	C

*= All positioning is determined as installed unit is viewed from the front.

C= If placed on combustible floor, floor MUST be wood only.

NC= For installation on non-combustible floors only. A combustible subbase must be used for installations on combustible flooring.

GCV9 MINIMUM CLEARANCES TO COMBUSTIBLE MATERIALS (INCHES)						
POSITION*	FRONT	SIDES	REAR	TOP	FLUE	FLOOR
Upflow	3	0	0	1	0	NC
Horizontal	3	6	0	6	0	C

*= All positioning is determined as installed unit is viewed from the front.

C= If placed on combustible floor, floor MUST be wood only.

NC= For installation on non-combustible floors only. A combustible subbase must be used for installations on combustible flooring.

36" at front is required for servicing or cleaning.

Note: In all cases accessibility clearance shall take precedence over clearances from the enclosure where accessibility clearances are greater. All dimensions are given in inches.

High Altitude Derate

When this furnace is installed at high altitude, the appropriate High Altitude orifice kit must be installed. This is required due to the natural reduction in the density of both the gas fuel and combustion air as altitude increases. The kit will provide the proper design certified input rate within the specified altitude range.

Furnace	"STANDARD" and "HIGH ALTITUDE" KITS								
	0 - 7,000 Feet (Standard Altitude)			7,001 - 9,000 Feet			9,001 - 11,000 Feet		
	Gas Orifices		ID Blwr Pressure Switch	Gas Orifices		ID Blwr Pressure Switch	Gas Orifices		ID Blwr Pressure Switch
	Natural	Propane		Natural	Propane		Natural	Propane	
GMV90704CXA	No Change	LPM-03* #55 Orifice	No Change	HA-02 #44 Orifice	HA-02 #56 Orifice	HAPS28	HA-02A #45 Orifice	HA-02A #56 Orifice	HAPS28
GMV90905DXA GMV91155DXA	No Change	LPM-03* #55 Orifice	No Change	HA-02A #44 Orifice	HA-02A #56 Orifice	HAPS29	HA-02A #45 Orifice	HA-02A #56 Orifice	HAPS29
GCV90704CXA GCV90905DXA	No Change	LPM-03* #55 Orifice	No Change	---	---	---	---	---	---

High altitude kits are purchased according to the installation altitude and usage of either natural or propane gas. Refer to the chart above for a tabular listing of appropriate altitude ranges and corresponding manufacturer's high altitude Natural Gas and Propane Gas kits. For a tabular listing of appropriate altitude ranges and corresponding manufacturer's High Altitude Pressure Switch kits, refer to either the *Pressure Switch Trip Points & Usage Chart* in this manual or the *Accessory Charts* in Service Instructions.

COMPONENT IDENTIFICATION

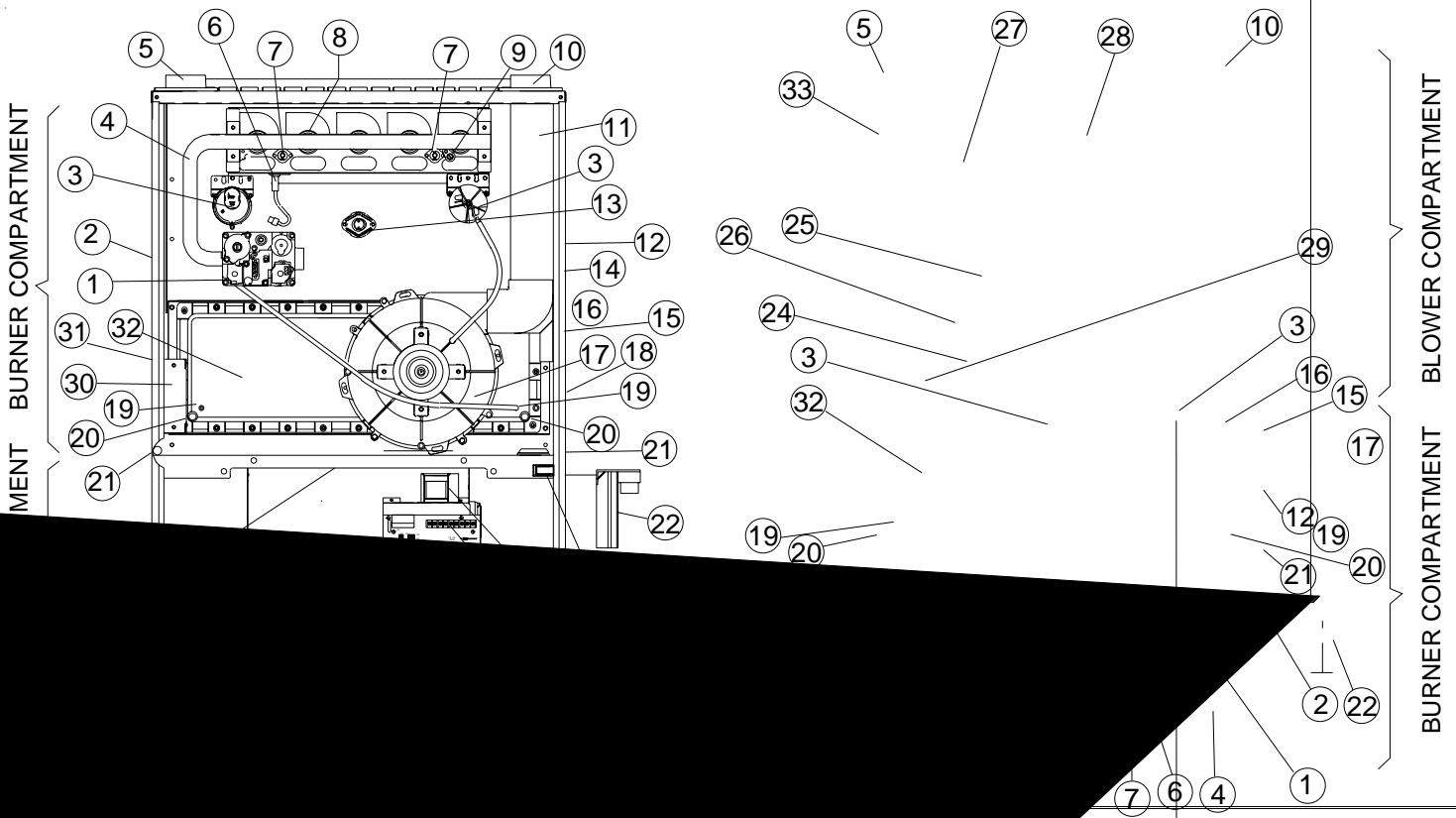

- 1 Induced Draft Blower
- 2 Electrical Connection Inlets (Alternate)
- 3 Electrical Connection Inlets
- 4 Combustion Air Inlet Pipe (ACV9 Only)
- 5 Coil Front Cover
- 6 Junction Box
- 7 Auxiliary Limits
- 8 Bottom Return Filter Retainer
- 9 ECM Variable Speed Circulator Blower
- 10 Transformer (40 VA)
- 11 24 Volt Thermostat Connections
- 12 Inductor (Not All Models)
- 13 Two-Stage Integrated Control Module (with fuse and diagnostic LED)
- 14 Blower Door Interlock Switch
- 15 Drain Trap
- 16 Gas Line Penetrations
- 17 Cover Drain Port
- 18 Water Pressure Tap
- 19
- 20
- 21
- 22
- 23
- 24
- 25
- 26
- 27
- 28
- 29
- 30
- 31
- 32
- 33
- 34

GMV9 _____ XA (Manufacturing Numbers P1257603-06F)
 GCV9 _____ XA (Manufacturing Numbers P1257803-05F)

PRODUCT DIMENSIONS

GMV9__XA

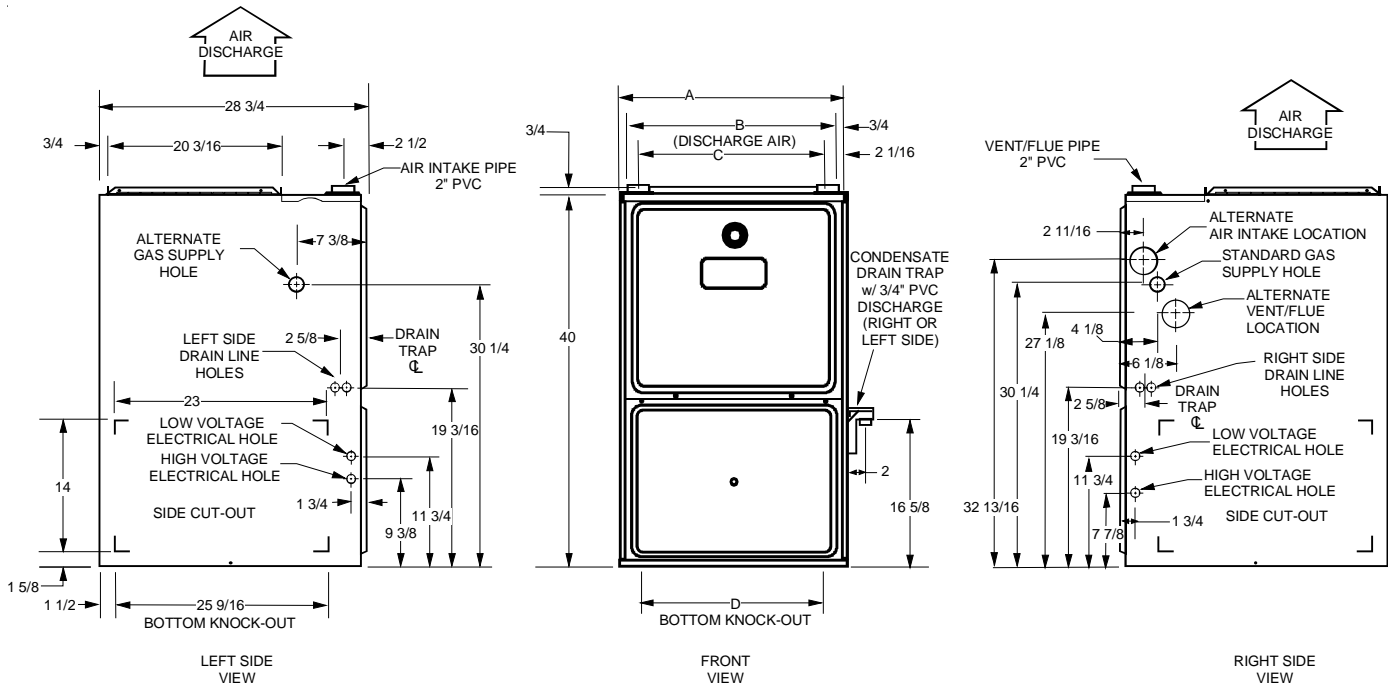

CABINET SIZE	UNITS	A	B	C	D
MEDIUM	0704CXA	21	19 1/2	16 3/8	13 5/8
LARGE	0905DXA	24 1/2	23	20 3/8	17 1/2
LARGE	1155DXA	24 1/2	23	20 3/8	20 7/8

All dimensions are in inches.

PRODUCT DIMENSIONS

GCV9____XA

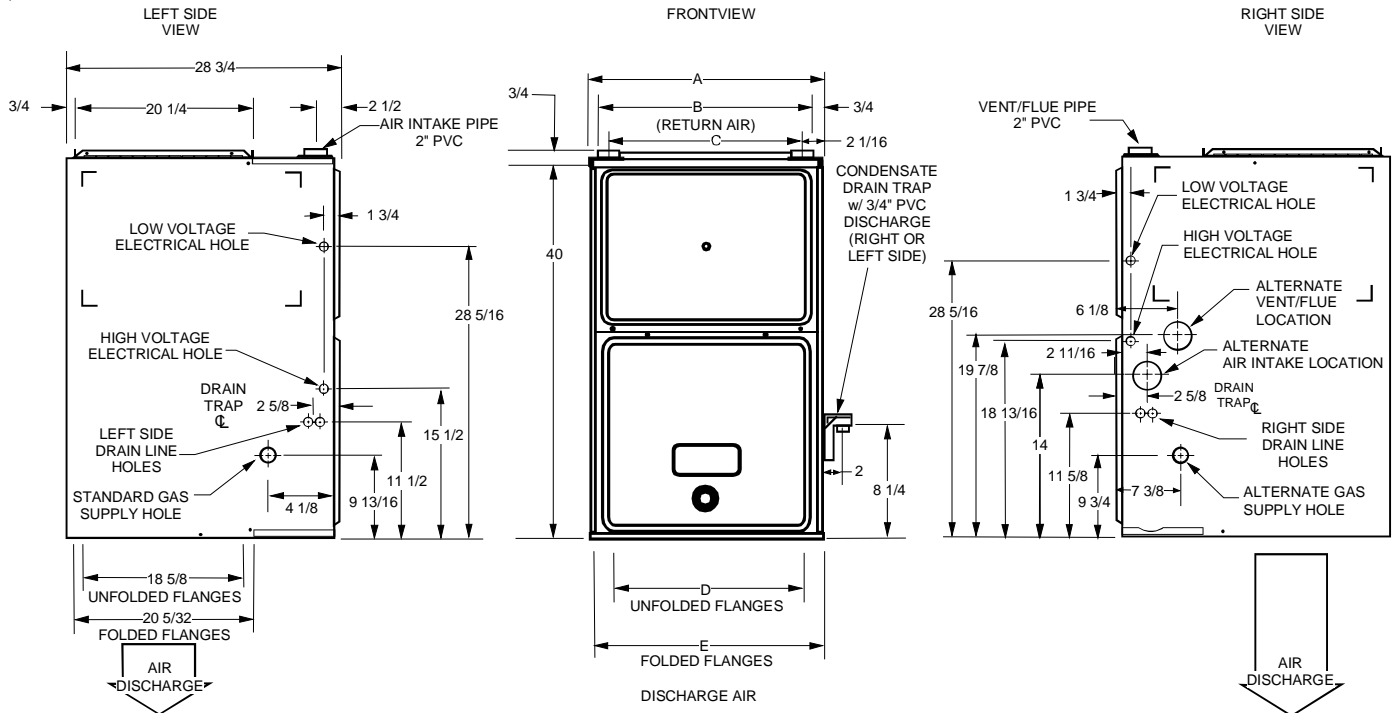

CABINET SIZE	UNITS	A	B	C	D	D
MEDIUM	0704CXA	21	19 1/2	16 3/8	18	19 1/2
LARGE	0905DXA	24 1/2	23	20 3/8	21 1/2	23

All dimensions are in inches.

PRODUCT DESIGN

PRESSURE SWITCH TRIP POINTS AND USAGE CHART								
MODEL	NEGATIVE PRESSURE ID BLOWER WITH FLUE NOT FIRING TYPICAL SEA LEVEL DATA		NEGATIVE PRESSURE ID BLOWER WITH FLUE FIRING TYPICAL SEA LEVEL DATA		NEGATIVE PRESSURE COIL COVER WITH FLUE NOT FIRING TYPICAL SEA LEVEL DATA		NEGATIVE PRESSURE COIL COVER WITH FLUE FIRING TYPICAL SEA LEVEL DATA	
	LOW FIRE	HIGH FIRE	LOW FIRE	HIGH FIRE	LOW FIRE	HIGH FIRE	LOW FIRE	HIGH FIRE
GMV90704CXA	-0.45	-0.90	-0.50	-0.95	-0.25	-0.25	-0.25	-0.25
GMV90905DXA GMV91155DXA	-0.65	-1.20	-0.70	-1.25	-0.25	-0.25	-0.25	-0.25
GCV90704CXA	-0.35	-0.35	-0.70	-0.75	-0.52	-0.52	-0.52	-0.52
GCV90904DXA	-0.35	-0.70	-0.40	-0.75	-0.52	-0.52	-0.52	-0.52

Note: The typical sea level negative pressure data represents the minimum pressures expected. Shorter length of flue pipe or single pipe systems compared to dual pipe systems should show higher (greater negative) pressures.

PRESSURE SWITCH TRIP POINTS AND USAGE CHART															
MODEL	0 to 7,000 ft.						7,001 ft. to 11,000 ft.								
	TRIP POINT COIL COVER PRESSURE SWITCH		COIL COVER PRESSURE SWITCH PART #	TRIP POINT ID BLOWER PRESSURE SWITCH		ID BLOWER PRESSURE SWITCH PART #	PS1 LABEL COLOR	PS2 LABEL COLOR	TRIP POINT COIL COVER PRESSURE SWITCH		TRIP POINT ID BLOWER PRESSURE SWITCH		HIGH ALTITUDE KIT	PS1 LABEL COLOR	PS2 LABEL COLOR
	LOW FIRE	HIGH FIRE		LOW FIRE	HIGH FIRE				LOW FIRE	HIGH FIRE	LOW FIRE	HIGH FIRE			
GMV90704CXA	-0.10	-0.10	20197301	-0.30	-0.75	11177113	PURPLE	PINK	-0.10	-0.10	-0.22	-0.55	HAPS28 11177115	GREEN	YELLOW
GMV90905DXA GMV91155DXA	-0.10	-0.10	20197301	-0.50	-1.10	11177114	WHITE	GRAY	-0.10	-0.10	-0.38	-0.82	HAPS29 11177116	ORANGE	LT BLUE
GCV90704CXA	-0.37	-0.37	20197306	-0.20	-0.55	11177118	GREEN	PURPLE	-0.37	-0.37	-0.15	-0.30	HAPS31 11177120	YELLOW	RED
GCV90905DXA	-0.37	-0.37	20197306	-0.20	-0.55	11177118	GREEN	PURPLE	-0.37	-0.37	-0.15	-0.30	HAPS31 11177120	YELLOW	RED

Note: All installations above 7,000 ft. require a pressure switch change. For installations in Canada the AMV9 & ACV9 furnaces are certified only to 4500 ft.

Note: Replacement pressure switch number is listed below high altitude kit number.

Note: All negative pressure readings are in inches of water column (" w.c.).

T.O.D. PRIMARY LIMIT				
Part Number	20162903	20162905	20162907	20162908
Open Setting (°F)	160	145	155	170
Color Code(s)	Blue	Yellow	Orange	Green
GMV90704CXA		1		
GMV90905DXA		1		
GMV91155DXA	1			
GCV90704CXA	1			
GCV90905DXA				1

PRODUCT DESIGN

ROLLOUT LIMIT SWITCHES				
Part Number	10123533	10123534	10123536	10123537
Open Setting (°F)	200	220	180	190
Color Code(s)	Yellow	Orange	Lt. Blue	Gray
GMV90704CXA				2
GMV90905DXA			2	
GMV91155DXA	2			
GCV90704CXA		2		
GCV90905DXA			2	

AUXILIARY LIMIT SWITCHES				
Part Number	10123517	10123533	10123534	10123537
Open Setting (°F)	210	200	220	190
Color Code(s)	White	Yellow	Orange	Gray
GMV90704BXA	2			
GMV90905DXA				2
GMV91155DXA		2		
GCV90704CXA			2	
GCV90905DXA	2			

PRODUCT DESIGN

Coil Matches:

A large array of Amana® brand coils are available for use with the new GCV9 furnaces, in either counterflow or horizontal applications & with GMV9 furnaces, in either upflow or horizontal applications. These coils are available in both cased and uncased models, with or without a TXV expansion device. These new 92%+ and 95%+ furnaces match up with the existing Amana® brand coils as shown in the chart below.

Coil Matches (for Amana® brand units using R22):

CABINET WIDTH	FURNACE MODELS	AIRFLOW (tons)	CAUF UNCASED "A" COILS	CAUX UNCASED TXV "A" COILS	CACF CASED "A" COILS	CAPF CASED "A" COILS	CAPX CASED TXV "A" COILS	CHPF HORIZ. CASED "A" COIL	CHPX HORIZ. CASED TXV "A" COIL
21	GMV90704CXA GCV90704CXA	1 1/2 - 4	CAUF042C2* CAUF048C2* CAUF049C2* CAUF060C2* CAUF061C2*	CAUX049C2*	CACF042C2* CACF048C2* CACF060C2* CACF061C2*	CAPF036C2* CAPF042C2*	CAPX049C2*		
24 1/2	GMV90905DXA GCV90905DXA GMV91155DXA GCV91155DXA	2 - 5	CAUF049D2* CAUF060D2* CAUF061D2*	CAUX049D2* CAUX060D2* CAUX061D2*	CACF060D2* CACF061D2*	CAPF049D2* CAPF060D2*	CAPX049D2* CAPX060D2* CAPX061D2*	CHPF048D2* CHPF060D2*	CHPX048D2* CHPX060D2*

Coil Matches (for the Amana RSD units using R-410A):

CABINET WIDTH	FURNACE MODELS	AIRFLOW (tons)	CAUF UNCASED "A" COILS	CAUX UNCASED TXV "A" COILS	CAPF CASED "A" COILS	CAPX CASED TXV "A" COILS	CHPF HORIZ. CASED "A" COIL	CHPX HORIZ. CASED TXV "A" COIL
21	GMV90704CXA GCV90704CXA	1 1/2 - 4	CAUF042C4* CAUF048C4* CAUF057D4*	CAUX042C4* CAUX048C4* CAUX057D4* CAUX060D4*	CAPF042C4*	CAPX042C4* CAPX048C4*		
24 1/2	GMV90905DXA GCV90905DXA GMV91155DXA GCV91155DXA	2 - 5		CAUX057D4* CAUX060D4*	CAPF057D4* CAPF060D4*	CAPX057D4* CAPX060D4*	CHPF048D4* CHPF060D4*	CHPX048D4* CHPX060D4*

PRODUCT DESIGN

Thermostats:

The following Amana® brand thermostats are suggested for use with GMV9 & GCV9 Furnace Models:

THERMOSTATS						
Thermostat	Man/Auto	Programmable	Cool	Heat	Batt. Powered	Batt. Bkup
1213406*	Man. Or Auto	Yes	2	3	No	No
1213407	Man. Changeover	Yes	2	2	Yes	Yes
1213411	Man. Changeover	No	2	2	Yes	No

*1213406 is the recommended model for the GMV9 & GCV9 furnaces when used with a heat pump in a fossil fuel application. It is NOT for use with either the GMV9 or GCV9 as a sole heating source. 1213406 thermostats are 24V powered with battery backup.

Filters:

Filters are required with this furnace and must be provided by the installer. The filters used must comply with UL900 or CAN/ULCS111 standards. Installing this furnace without filters will void the unit warranty

Upflow Filters

This furnace has provisions for the installation of return air filters at the side and/or bottom return. The furnace will accommodate the following filter sizes depending on cabinet size:

SIDE RETURN		
Cabinet Width (in.)	Nominal Filter Size (in.)	Approx. Flow Area (in ²)
All	16 x 25 x 1	400

BOTTOM RETURN		
Cabinet Width (in.)	Nominal Filter Size (in.)	Approx. Flow Area (in ²)
17-1/2	14 x 25 x 1	350
21	16 x 25 x 1	400
24-1/2	20 x 25 x 1	500

Refer to Minimum Filter Area tables to determine filter area requirement. **NOTE:** Filters can also be installed elsewhere in the duct system such as a central return.

		UPFLOW COOLING AIRFLOW REQUIREMENT (CFM)						
		600	800	1000	1200	1400	1600	2000
Input Airflow	0704_XA	---	---	564*	564*	672	768	
	0905_XA	---	---	---	752*	752*	768	960
	1155_XA	---	---	---	940*	940*	940*	960

		UPFLOW COOLING AIRFLOW REQUIREMENT (CFM)						
		600	800	1000	1200	1400	1600	2000
Input Airflow	0704_XA	---	---	627*	627*	672	768	---
	0905_XA	---	---	---	836*	836*	836*	960
	1155_XA	---	---	---	940*	940*	940*	960

		COUNTERFLOW COOLING AIRFLOW REQUIREMENT (CFM)						
		600	800	1000	1200	1400	1600	2000
Input Airflow	0704_XA	---	---	641*	641*	672	768	---
	0905_XA	---	---	---	854*	854*	854*	960

		COUNTERFLOW COOLING AIRFLOW REQUIREMENT (CFM)						
		600	800	1000	1200	1400	1600	2000
Input Airflow	0704_XA	---	---	320*	320*	336	384	---
	0905_XA	---	---	---	427*	427*	427*	480

*Minimum filter area dictated by heating airflow requirement.

*Minimum filter area dictated by heating airflow requirement.

Disposable Minimum Filter Area (in²)

[Based on a 300 ft/min filter face velocity]

Permanent Minimum Filter Area (in²)

[Based on 600 ft/min filter face velocity]

PRODUCT DESIGN

Counterflow Filters

This furnace has provisions for the installation of return air filters at the counterflow top return. The furnace will accommodate the following filter sizes depending on cabinet size:

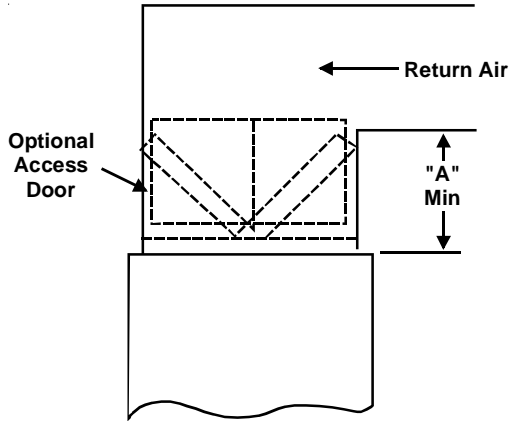

Counterflow Top Return				
Cabinet Width	Filter Area (in ²)	Qty	Filter Size (in)	Dimension "A" (in)
21	600	2	15 X 20 X 1	13.0
24 1/2				11.3
21	800	2	20 X 20 X 1	18.8
24 1/2				17.7
21	1000	2	25 X 20 X 1	24.3
24 1/2				23.4

Refer to Minimum Filter Area tables to determine filter area requirement. **NOTE:** Filters can also be installed elsewhere in the duct system such as a central return.

FURNACE SPECIFICATIONS

MODEL	GMV90704CXA	GMV90905DXA	GMV91155DXA
Btuh Input (US) High Fire	69,000	92,000	115,000
Output (US) High Fire	64,200	84,000	106,500
Btuh Input (US) Low Fire	48,000	64,000	80,000
Output (US) Low Fire	44,600	59,500	74,400
A.F.U.E.	93%	93%	93%
Rated External Static (" w.c.)	.10 - .50	.10 - .50	.10 - .50
Temperature Rise (°F)	30 - 60	30 - 60	35 - 65
High Stage Pressure Switch Trip Point (" w.c.)	-0.75	-1.10	-1.10
Low Stage Pressure Switch Trip Point (" w.c.)	-0.30	-0.50	-0.50
Front Cover Pressure Switch Trip Point (" w.c.)	-0.10	-0.10	-0.10
Blower Wheel (D" x W")	10 x 10	11 x 10	11 x 10
Blower Horsepower	3/4	1	1
Blower Speeds	Refer to airflow charts on pages 15-19.		
Max CFM @ 0.5 E.S.P.			
Power Supply	115-60-1	115-60-1	115-60-1
Minimum Circuit Ampacity (MCA)	12.8	14.6	14.6
Maximum Overcurrent Device	15	15	15
Transformer (VA)	40	40	40
Heat Anticipator (Amps)	0.7	0.7	0.7
Primary Limit Setting (°F)	155	145	160
Auxiliary Limit Setting (°F)	190	180	200
Rollout Limit Setting (°F)	200	190	200
Fan Delay On Heating	30 secs.	30 secs.	30 secs.
Off Heating *	150 secs.	150 secs.	150 secs.
Fan Delay On Cooling	5 secs.	5 secs.	5 secs.
Off Cooling	45 secs.	45 secs.	45 secs.
Fan Delay On - Fan Only	5 secs.	5 secs.	5 secs.
Gas Supply Pressure (Natural/Propane) (" w.c.)	7 / 11	7 / 11	7 / 11
Manifold Pressure (Natural/Propane) High Stage (" w.c.)	3.5 / 10	3.5 / 10	3.5 / 10
Manifold Pressure (Natural/Propane) Low Stage ("w.c.)	1.9 / 6.0	1.9 / 6.0	1.9 / 6.0
Orifice Size (Natural/Propane)	#43 / #55	#43 / #55	#43 / #55
Number of Burners	68	4	5
Vent Connector Diameter (inches)	2	3	3
Combustion Air Connector Diameter (inches)	2	3	3
Shipping Weight (lbs.)	135	172	175

* Off Heating - This fan delay timing is adjustable (90, 120, 150 or 180 seconds), 150 seconds as shipped.

1. These furnaces are manufactured for natural gas operation. Optional Kits are available for conversion to propane gas operation.
2. For elevations above 2000 ft. the rating should be reduced by 4% for each 1000 ft. above sea level. The furnace must not be derated, orifice changes should only be made if necessary for altitude.
3. The total heat loss from the structure as expressed in TOTAL BTU/HR must be calculated by the manufactures method in accordance with the "A.S.H.R.A.E. GUIDE" or "MANUAL J-LOAD CALCULATIONS" published by the AIR CONDITIONING CONTRACTORS OF AMERICA. The total heat loss calculated should be equal to or less than the heating capacity. Output based on D.O.E. test procedures, steady state efficiency times output.
4. Minimum Circuit Ampacity calculated as: (1.25 x Circulator Blower Amps) + I.D. Blower Amps.

FURNACE SPECIFICATIONS

MODEL	GCV90704CXA	GCV90905DXA
Btuh Input (US) High Fire	69,000	92,000
Output (US) High Fire	64,200	84,000
Btuh Input (US) Low Fire	48,000	64,000
Output (US) Low Fire	45,000	60,100
A.F.U.E.	93%	93%
Rated External Static (" w.c.)	.10 - .50	.10 - .50
Temperature Rise (°F)	30 - 60	30 - 60
High Stage Pressure Switch Trip Point (" w.c.)	-0.55	-0.55
Low Stage Pressure Switch Trip Point (" w.c.)	-0.20	-0.20
Front Cover Pressure Switch Trip Point (" w.c)	-0.37	-0.37
Blower Wheel (D" x W")	10 x 10	11 x 10
Blower Horsepower	3/4	1
Blower Speeds	Refer to airflow charts on pages 15-19.	
Max CFM @ 0.5 E.S.P.		
Power Supply	115-60-1	115-60-1
Minimum Circuit Ampacity (MCA)	12.8	14.6
Maximum Overcurrent Device	15	15
Transformer (VA)	40	40
Heat Anticipator (Amps)	0.7	0.7
Primary Limit Setting (°F)	160	170
Auxiliary Limit Setting (°F)	220	180
Rollout Limit Setting (°F)	220	210
Fan Delay On Heating	30 secs.	30 secs.
Off Heating *	150 secs.	150 secs.
Fan Delay On Cooling	5 secs.	5 secs.
Off Cooling	45 secs.	45 secs.
Fan Delay On - Fan Only	5 secs.	5 secs.
Gas Supply Pressure (Natural/Propane) (" w.c.)	7 / 11	7 / 11
Manifold Pressure (Natural/Propane) High Stage (" w.c.)	3.5 / 10	3.5 / 10
Manifold Pressure (Natural/Propane) Low Stage ("w.c.)	1.9 / 6.0	1.9 / 6.0
Orifice Size (Natural/Propane)	#43 / #55	#43 / #55
Number of Burners	3	4
Vent Connector Diameter (inches)	2	3
Combustion Air Connector Diameter (inches)	2	2
Shipping Weight (lbs.)	135	172

* Off Heating - This fan delay timing is adjustable (90, 120, 150 or 180 seconds), 150 seconds as shipped.

1. These furnaces are manufactured for natural gas operation. Optional Kits are available for conversion to propane gas operation.
2. For elevations above 2000 ft. the rating should be reduced by 4% for each 1000 ft. above sea level. The furnace must not be derated, orifice changes should only be made if necessary for altitude.
3. The total heat loss from the structure as expressed in TOTAL BTU/HR must be calculated by the manufactures method in accordance with the "A.S.H.R.A.E. GUIDE" or "MANUAL J-LOAD CALCULATIONS" published by the AIR CONDITIONING CONTRACTORS OF AMERICA. The total heat loss calculated should be equal to or less than the heating capacity. Output based on D.O.E. test procedures, steady state efficiency times output.
4. Minimum Circuit Ampacity calculated as: (1.25 x Circulator Blower Amps) + I.D. Blower Amps.

BLOWER PERFORMANCE SPECIFICATIONS

GMV9 Heating Speed Charts

GMV90704CXA (Rise Range: 30 - 60°F)					GMV90905DXA (Rise Range: 30 - 60°F)				
Heating Speed Tap	Adjust Tap	Low Stage CFM at .1" - .5" w.c. ESP	High Stage CFM at .1" - .5" w.c. ESP	Rise (°F)	Heating Speed Tap	Adjust Tap	Low Stage CFM at .1" - .5" w.c. ESP	High Stage CFM at .1" - .5" w.c. ESP	Rise (°F)
A	Minus(-)	756	1089	56	A	Minus(-)	1013	1458	56
	Normal	840	1210	50		Normal	1125	1620	50
	Plus (+)	924	1331	46		Plus (+)	1238	1782	45
B	Minus(-)	828	1192	51	B	Minus(-)	1076	1549	52
	Normal	920	1325	46		Normal	1195	1721	47
	Plus (+)	1012	1457	42		Plus (+)	1315	1893	43
C	Minus(-)	900	1296	47	C	Minus(-)	1139	1639	49
	Normal	1000	1440	42		Normal	1265	1822	44
	Plus (+)	1100	1584	38		Plus (+)	1392	2004	40
D	Minus(-)	972	1400	43	D	Minus(-)	1202	1730	47
	Normal	1080	1555	39		Normal	1335	1922	42
	Plus (+)	1188	1711	35		Plus (+)	1469	2115	38

GMV91155DXA (Rise Range: 30 - 60°F)				
Heating Speed Tap	Adjust Tap	Low Stage CFM at .1" - .5" w.c. ESP	High Stage CFM at .1" - .5" w.c. ESP	Rise (°F)
A	Minus(-)	1107	1594	63
	Normal	1230	1771	57
	Plus (+)	1353	1948	52
B	Minus(-)	1139	1639	62
	Normal	1265	1822	56
	Plus (+)	1392	2004	50
C	Minus(-)	1170	1685	60
	Normal	1300	1872	54
	Plus (+)	1430	2059	49
D	Minus(-)	1202	1730	58
	Normal	1335	1922	53
	Plus (+)	1469	2115	48

- Units are shipped without filter(s). CFM in chart is without filter(s).
- All furnaces shipped with heating speed set at "B" and cooling speed set at "D". Installer should adjust blower speed as needed. The first task is to determine the proper airflow for the cooling system.
- For most cooling applications, about 400 CFM per ton is desirable.
- The chart is for information only. For satisfactory operation, external static pressure not to exceed value shown on rating plate.
- Do not operate above 0.5" w.c. ESP in heating mode. Operating between 0.5" w.c. and 0.8" w.c. is tabulated for cooling purposes only.
- * Motor CFM minimum.

BLOWER PERFORMANCE SPECIFICATIONS

GMV9 High (Single) Stage Cooling Speed Charts

GMV90704CXA			GMV90905DXA			GMV91155DXA		
Cooling Speed Tap	Adjust Tap	CFM at .1" - .8" w.c. ESP	Cooling Speed Tap	Adjust Tap	CFM at .1" - .8" w.c. ESP	Cooling Speed Tap	Adjust Tap	CFM at .1" - .8" w.c. ESP
A	Minus(-)	540	A	Minus(-)	720	A	Minus(-)	720
	Normal	600		Normal	800		Normal	800
	Plus (+)	660		Plus (+)	880		Plus (+)	880
B	Minus(-)	720	B	Minus(-)	990	B	Minus(-)	990
	Normal	800		Normal	1100		Normal	1100
	Plus (+)	880		Plus (+)	1210		Plus (+)	1210
C	Minus(-)	990	C	Minus(-)	1260	C	Minus(-)	1260
	Normal	1100		Normal	1400		Normal	1400
	Plus (+)	1210		Plus (+)	1540		Plus (+)	1540
D	Minus(-)	1286	D	Minus(-)	1620	D	Minus(-)	1620
	Normal	1429		Normal	1800		Normal	1800
	Plus (+)	1572		Plus (+)	1980		Plus (+)	1980

GMV9 Low Stage Cooling Speed Charts

GMV90704CXA			GMV90905DXA			GMV91155DXA		
Cooling Speed Tap	Adjust Tap	CFM at .1" - .8" w.c. ESP	Cooling Speed Tap	Adjust Tap	CFM at .1" - .8" w.c. ESP	Cooling Speed Tap	Adjust Tap	CFM at .1" - .8" w.c. ESP
A	Minus(-)	378*	A	Minus(-)	513*	A	Minus(-)	514*
	Normal	390		Normal	520		Normal	520
	Plus (+)	429		Plus (+)	572		Plus (+)	572
B	Minus(-)	468	B	Minus(-)	644	B	Minus(-)	644
	Normal	520		Normal	715		Normal	715
	Plus (+)	572		Plus (+)	787		Plus (+)	787
C	Minus(-)	644	C	Minus(-)	819	C	Minus(-)	819
	Normal	715		Normal	910		Normal	910
	Plus (+)	787		Plus (+)	1001		Plus (+)	1001
D	Minus(-)	836	D	Minus(-)	1053	D	Minus(-)	1053
	Normal	929		Normal	1170		Normal	1170
	Plus (+)	1022		Plus (+)	1287		Plus (+)	1287

- Units are shipped without filter(s). CFM in chart is without filter(s).
- All furnaces shipped with heating speed set at "B" and cooling speed set at "D". Installer should adjust blower speed as needed. The first task is to determine the proper airflow for the cooling system.
- For most cooling applications, about 400 CFM per ton is desirable.
- The chart is for information only. For satisfactory operation, external static pressure not to exceed value shown on rating plate.
- Do not operate above 0.5" w.c. ESP in heating mode. Operating between 0.5" w.c. and 0.8" w.c. is tabulated for cooling purposes only.
- * Motor CFM minimum.

BLOWER PERFORMANCE SPECIFICATIONS

GMV9 Continuous Fan Speed Chart

GMV90704CXA			GMV90905DXA			GMV91155DXA		
Cooling Speed Tap	Adjust Tap	CFM at .1" - .8" w.c. ESP	Cooling Speed Tap	Adjust Tap	CFM at .1" - .8" w.c. ESP	Cooling Speed Tap	Adjust Tap	CFM at .1" - .8" w.c. ESP
A	Minus(-)	380*	A	Minus(-)	513*	A	Minus(-)	514*
	Normal	380*		Normal	513*		Normal	514*
	Plus (+)	380*		Plus (+)	513*		Plus (+)	514*
B	Minus(-)	403	B	Minus(-)	554	B	Minus(-)	554
	Normal	448		Normal	616		Normal	616
	Plus (+)	493		Plus (+)	678		Plus (+)	678
C	Minus(-)	554	C	Minus(-)	706	C	Minus(-)	706
	Normal	616		Normal	784		Normal	784
	Plus (+)	678		Plus (+)	862		Plus (+)	862
D	Minus(-)	720	D	Minus(-)	907	D	Minus(-)	907
	Normal	800		Normal	1008		Normal	1008
	Plus (+)	880		Plus (+)	1109		Plus (+)	1109

1. Units are shipped without filter(s). CFM in chart is without filter(s).
2. All furnaces shipped with heating speed set at "B" and cooling speed set at "D". Installer should adjust blower speed as needed. The first task is to determine the proper airflow for the cooling system.
3. For most cooling applications, about 400 CFM per ton is desirable.
4. The chart is for information only. For satisfactory operation, external static pressure not to exceed value shown on rating plate.
5. Do not operate above 0.5" w.c. ESP in heating mode. Operating between 0.5" w.c. and 0.8" w.c. is tabulated for cooling purposes only.
6. * Motor CFM minimum.

BLOWER PERFORMANCE SPECIFICATIONS

GCV9 Heating Speed Charts

GCV90704CXA (Rise Range: 30 - 60°F)					GCV90905DXA (Rise Range: 30 - 60°F)				
Heating Speed Tap	Adjust Tap	Low Stage CFM at .1" - .5" w.c. ESP	High Stage CFM at .1" - .5" w.c. ESP	Rise (°F)	Heating Speed Tap	Adjust Tap	Low Stage CFM at .1" - .5" w.c. ESP	High Stage CFM at .1" - .5" w.c. ESP	Rise (°F)
A	Minus(-)	747	1076	56	A	Minus(-)	999	1439	56
	Normal	830	1195	50		Normal	1110	1598	50
	Plus (+)	913	1315	46		Plus (+)	1221	1758	46
B	Minus(-)	824	1186	51	B	Minus(-)	1067	1536	52
	Normal	915	1318	46		Normal	1185	1706	47
	Plus (+)	1007	1449	42		Plus (+)	1303	1876	43
C	Minus(-)	900	1296	47	C	Minus(-)	1134	1633	49
	Normal	1000	1440	42		Normal	1260	1814	44
	Plus (+)	1100	1584	38		Plus (+)	1386	1996	40
D	Minus(-)	978	1408	43	D	Minus(-)	1202	1730	46
	Normal	1085	1562	39		Normal	1335	1922	42
	Plus (+)	1194	1719	35		Plus (+)	1469	2115	38

GMV9/GCV9 Circulator Blower Speed Adjustment Switches

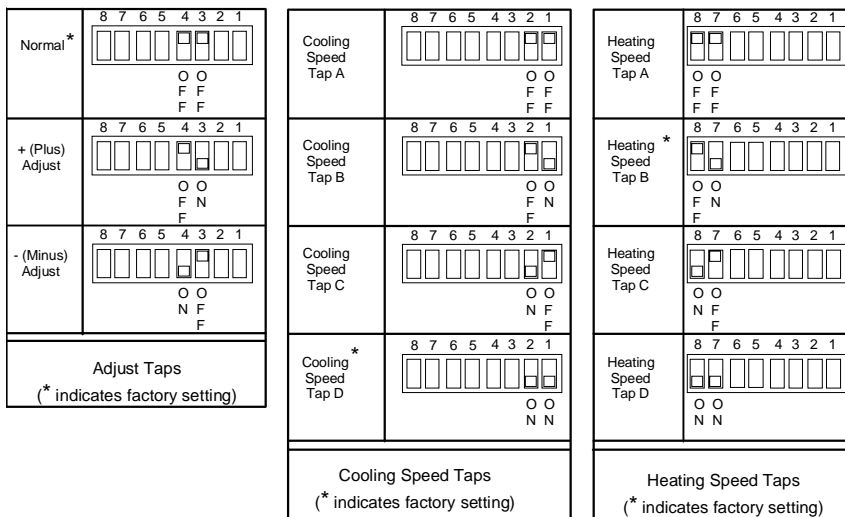

Note: There is a green LED adjacent to the integrated control module fuse which is used to verify airflow volume. The green CFM LED blinks once for each 100 CFM of airflow.

Example: 10 blinks = 1,000 CFM

Note: Continuous fan speed will be 56% of high stage cooling speed.

Example: 1,000 CFM of cooling speed will be reduced to 560 CFM when fan selector switch is set to on, and no call for cooling.

- Units are shipped without filter(s). CFM in chart is without filter(s).
- All furnaces shipped with heating speed set at "B" and cooling speed set at "D". Installer should adjust blower speed as needed. The first task is to determine the proper airflow for the cooling system.
- For most cooling applications, about 400 CFM per ton is desirable.
- The chart is for information only. For satisfactory operation, external static pressure not to exceed value shown on rating plate.
- Do not operate above 0.5" w.c. ESP in heating mode. Operating between 0.5" w.c. and 0.8" w.c. is tabulated for cooling purposes only.
- * Motor CFM minimum.

BLOWER PERFORMANCE SPECIFICATIONS

GMV9/GCV9 Ramping Profile

Ramping* Profile Tap A	<table border="1"> <tr><td>8</td><td>7</td><td>6</td><td>5</td><td>4</td><td>3</td><td>2</td><td>1</td></tr> <tr><td><input type="checkbox"/></td><td><input type="checkbox"/></td><td><input type="checkbox"/></td><td><input type="checkbox"/></td><td><input type="checkbox"/></td><td><input type="checkbox"/></td><td><input type="checkbox"/></td><td><input type="checkbox"/></td></tr> <tr><td></td><td></td><td>O</td><td>O</td><td></td><td></td><td></td><td></td></tr> <tr><td></td><td></td><td>F</td><td>F</td><td></td><td></td><td></td><td></td></tr> <tr><td></td><td></td><td>F</td><td>F</td><td></td><td></td><td></td><td></td></tr> </table>	8	7	6	5	4	3	2	1	<input type="checkbox"/>	<input type="checkbox"/>	<input type="checkbox"/>	<input type="checkbox"/>	<input type="checkbox"/>	<input type="checkbox"/>	<input type="checkbox"/>	<input type="checkbox"/>			O	O							F	F							F	F				
8	7	6	5	4	3	2	1																																		
<input type="checkbox"/>	<input type="checkbox"/>	<input type="checkbox"/>	<input type="checkbox"/>	<input type="checkbox"/>	<input type="checkbox"/>	<input type="checkbox"/>	<input type="checkbox"/>																																		
		O	O																																						
		F	F																																						
		F	F																																						
Ramping Profile Tap B	<table border="1"> <tr><td>8</td><td>7</td><td>6</td><td>5</td><td>4</td><td>3</td><td>2</td><td>1</td></tr> <tr><td><input type="checkbox"/></td><td><input type="checkbox"/></td><td><input type="checkbox"/></td><td><input type="checkbox"/></td><td><input type="checkbox"/></td><td><input type="checkbox"/></td><td><input type="checkbox"/></td><td><input type="checkbox"/></td></tr> <tr><td></td><td></td><td>O</td><td>O</td><td></td><td></td><td></td><td></td></tr> <tr><td></td><td></td><td>F</td><td>N</td><td></td><td></td><td></td><td></td></tr> <tr><td></td><td></td><td>F</td><td></td><td></td><td></td><td></td><td></td></tr> </table>	8	7	6	5	4	3	2	1	<input type="checkbox"/>	<input type="checkbox"/>	<input type="checkbox"/>	<input type="checkbox"/>	<input type="checkbox"/>	<input type="checkbox"/>	<input type="checkbox"/>	<input type="checkbox"/>			O	O							F	N							F					
8	7	6	5	4	3	2	1																																		
<input type="checkbox"/>	<input type="checkbox"/>	<input type="checkbox"/>	<input type="checkbox"/>	<input type="checkbox"/>	<input type="checkbox"/>	<input type="checkbox"/>	<input type="checkbox"/>																																		
		O	O																																						
		F	N																																						
		F																																							
Ramping Profile Tap C	<table border="1"> <tr><td>8</td><td>7</td><td>6</td><td>5</td><td>4</td><td>3</td><td>2</td><td>1</td></tr> <tr><td><input type="checkbox"/></td><td><input type="checkbox"/></td><td><input type="checkbox"/></td><td><input type="checkbox"/></td><td><input type="checkbox"/></td><td><input type="checkbox"/></td><td><input type="checkbox"/></td><td><input type="checkbox"/></td></tr> <tr><td></td><td></td><td>O</td><td>O</td><td></td><td></td><td></td><td></td></tr> <tr><td></td><td></td><td>N</td><td>F</td><td></td><td></td><td></td><td></td></tr> <tr><td></td><td></td><td>F</td><td></td><td></td><td></td><td></td><td></td></tr> </table>	8	7	6	5	4	3	2	1	<input type="checkbox"/>	<input type="checkbox"/>	<input type="checkbox"/>	<input type="checkbox"/>	<input type="checkbox"/>	<input type="checkbox"/>	<input type="checkbox"/>	<input type="checkbox"/>			O	O							N	F							F					
8	7	6	5	4	3	2	1																																		
<input type="checkbox"/>	<input type="checkbox"/>	<input type="checkbox"/>	<input type="checkbox"/>	<input type="checkbox"/>	<input type="checkbox"/>	<input type="checkbox"/>	<input type="checkbox"/>																																		
		O	O																																						
		N	F																																						
		F																																							
Ramping Profile Tap D	<table border="1"> <tr><td>8</td><td>7</td><td>6</td><td>5</td><td>4</td><td>3</td><td>2</td><td>1</td></tr> <tr><td><input type="checkbox"/></td><td><input type="checkbox"/></td><td><input type="checkbox"/></td><td><input type="checkbox"/></td><td><input type="checkbox"/></td><td><input type="checkbox"/></td><td><input type="checkbox"/></td><td><input type="checkbox"/></td></tr> <tr><td></td><td></td><td>O</td><td>O</td><td></td><td></td><td></td><td></td></tr> <tr><td></td><td></td><td>N</td><td>N</td><td></td><td></td><td></td><td></td></tr> </table>	8	7	6	5	4	3	2	1	<input type="checkbox"/>	<input type="checkbox"/>	<input type="checkbox"/>	<input type="checkbox"/>	<input type="checkbox"/>	<input type="checkbox"/>	<input type="checkbox"/>	<input type="checkbox"/>			O	O							N	N												
8	7	6	5	4	3	2	1																																		
<input type="checkbox"/>	<input type="checkbox"/>	<input type="checkbox"/>	<input type="checkbox"/>	<input type="checkbox"/>	<input type="checkbox"/>	<input type="checkbox"/>	<input type="checkbox"/>																																		
		O	O																																						
		N	N																																						
Ramping Profiles (* indicates factory setting)																																									

Note: The multi-speed circulator blower also offers several custom ON/OFF ramping profiles. These profiles may be used to enhance cooling performance and increase comfort level. The ramping profiles are selected using DIP switches 5 and 6.

Verify profile selection by counting the green CFM LED blinks and timing each step of the ramping profile.

GCV9 Continuous Fan Speed Chart

GCV90704CXA			GCV90905DXA		
Cooling Speed Tap	Adjust Tap	CFM at .1" - .8" w.c. ESP	Cooling Speed Tap	Adjust Tap	CFM at .1" - .8" w.c. ESP
A	Minus(-)	380*	A	Minus(-)	513*
	Normal	380*		Normal	513*
	Plus (+)	380*		Plus (+)	513*
B	Minus(-)	403	B	Minus(-)	554
	Normal	448		Normal	616
	Plus (+)	493		Plus (+)	678
C	Minus(-)	554	C	Minus(-)	706
	Normal	616		Normal	784
	Plus (+)	678		Plus (+)	862
D	Minus(-)	720	D	Minus(-)	907
	Normal	800		Normal	1008
	Plus (+)	880		Plus (+)	1109

- Units are shipped without filter(s). CFM in chart is without filter(s).
- All furnaces shipped with heating speed set at "B" and cooling speed set at "D". Installer should adjust blower speed as needed. The first task is to determine the proper airflow for the cooling system.
- For most cooling applications, about 400 CFM per ton is desirable.
- The chart is for information only. For satisfactory operation, external static pressure not to exceed value shown on rating plate.
- Do not operate above 0.5" w.c. ESP in heating mode. Operating between 0.5" w.c. and 0.8" w.c. is tabulated for cooling purposes only.
- * Motor CFM minimum.

BLOWER PERFORMANCE SPECIFICATIONS

GCV9 High (Single) Stage Cooling Speed Charts

GCV90704CXA			GCV90905DXA		
Cooling Speed Tap	Adjust Tap	CFM at .1" - .8" w.c. ESP	Cooling Speed Tap	Adjust Tap	CFM at .1" - .8" w.c. ESP
A	Minus(-)	540	A	Minus(-)	720
	Normal	600		Normal	800
	Plus (+)	660		Plus (+)	880
B	Minus(-)	720	B	Minus(-)	990
	Normal	800		Normal	1100
	Plus (+)	880		Plus (+)	1210
C	Minus(-)	990	C	Minus(-)	1260
	Normal	1100		Normal	1400
	Plus (+)	1210		Plus (+)	1540
D	Minus(-)	1286	D	Minus(-)	1620
	Normal	1429		Normal	1800
	Plus (+)	1572		Plus (+)	1980

GCV9 Low Stage Cooling Speed Charts

GCV90704CXA			GCV90905DXA		
Cooling Speed Tap	Adjust Tap	CFM at .1" - .8" w.c. ESP	Cooling Speed Tap	Adjust Tap	CFM at .1" - .8" w.c. ESP
A	Minus(-)	378*	A	Minus(-)	513*
	Normal	390		Normal	520
	Plus (+)	429		Plus (+)	572
B	Minus(-)	468	B	Minus(-)	644
	Normal	520		Normal	715
	Plus (+)	572		Plus (+)	787
C	Minus(-)	644	C	Minus(-)	819
	Normal	715		Normal	910
	Plus (+)	787		Plus (+)	1001
D	Minus(-)	836	D	Minus(-)	1053
	Normal	929		Normal	1170
	Plus (+)	1022		Plus (+)	1287

- Units are shipped without filter(s). CFM in chart is without filter(s).
- All furnaces shipped with heating speed set at "B" and cooling speed set at "D". Installer should adjust blower speed as needed. The first task is to determine the proper airflow for the cooling system.
- For most cooling applications, about 400 CFM per ton is desirable.
- The chart is for information only. For satisfactory operation, external static pressure not to exceed value shown on rating plate.
- Do not operate above 0.5" w.c. ESP in heating mode. Operating between 0.5" w.c. and 0.8" w.c. is tabulated for cooling purposes only.
- * Motor CFM minimum.

BTU OUTPUT vs TEMPERATURE RISE CHART

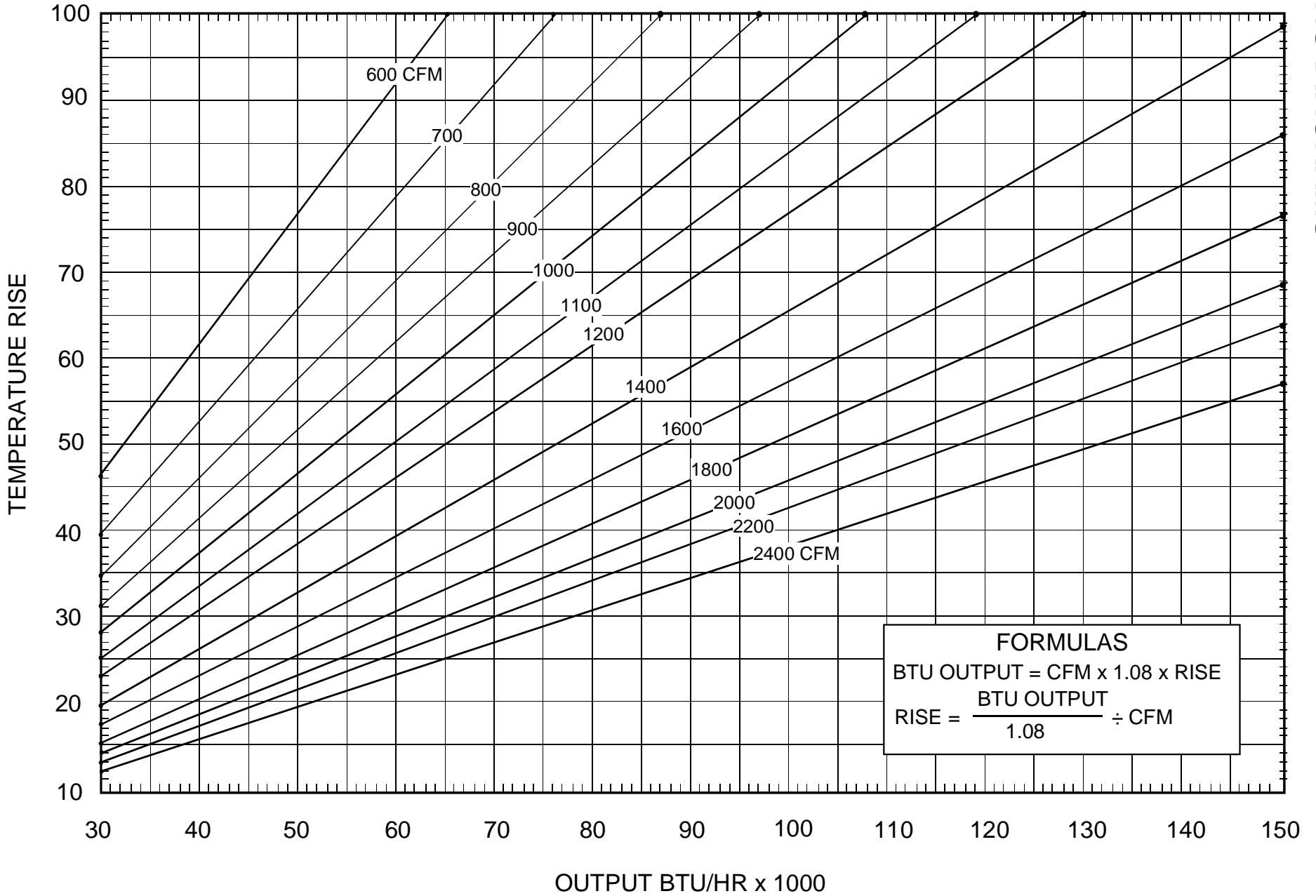

SCHEMATICS



WARNING

TO AVOID POSSIBLE ELECTRICAL SHOCK, PERSONAL INJURY, OR DEATH, DISCONNECT THE POWER BEFORE SERVICING.

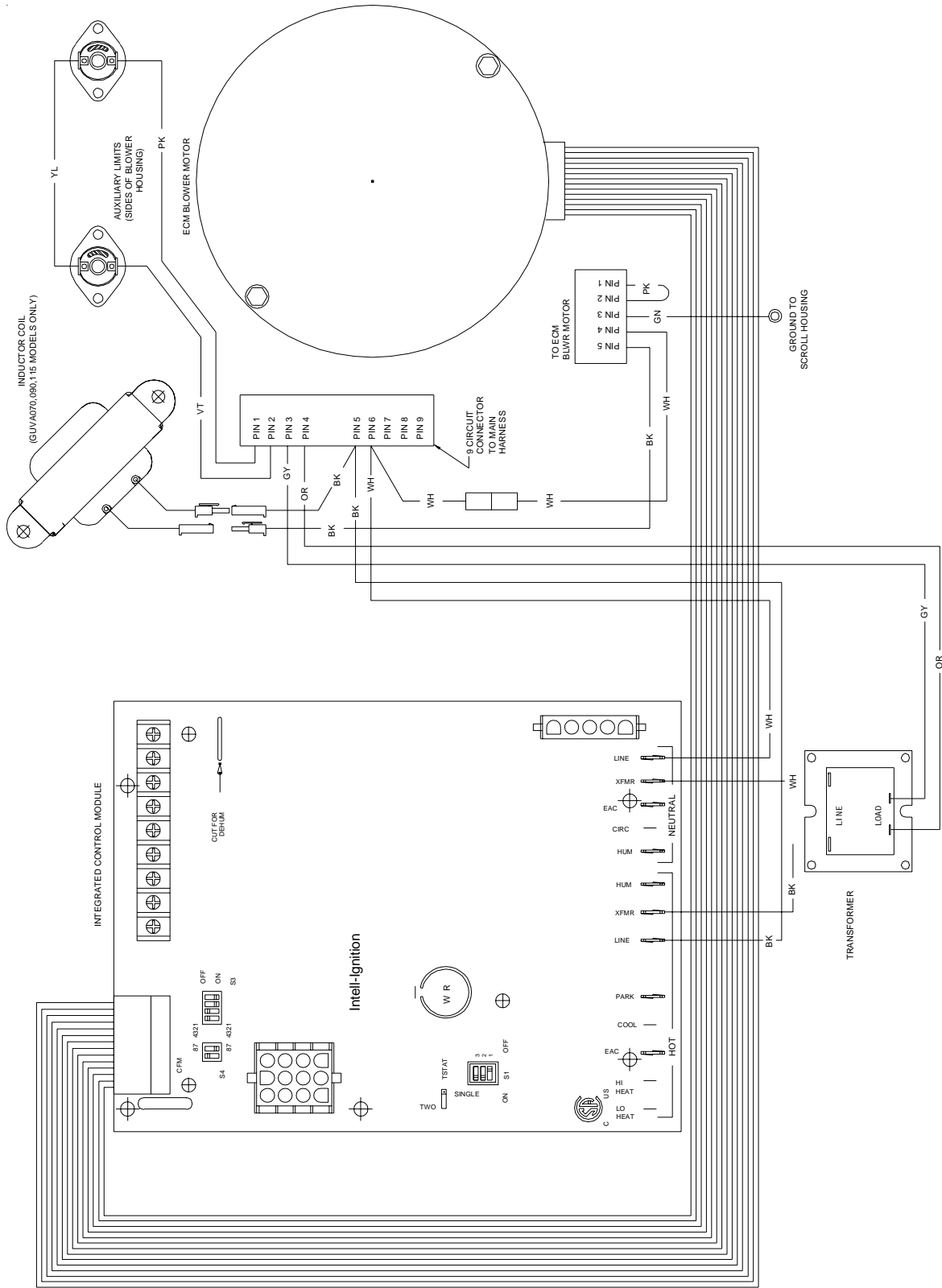

BLOWER ASSEMBLY SCHEMATIC
GMV9/GCV9____XA MODEL FURNACES
 This schematic is for reference only. Not all wiring is as shown above,
 refer to the appropriate wiring diagram for the unit being serviced.

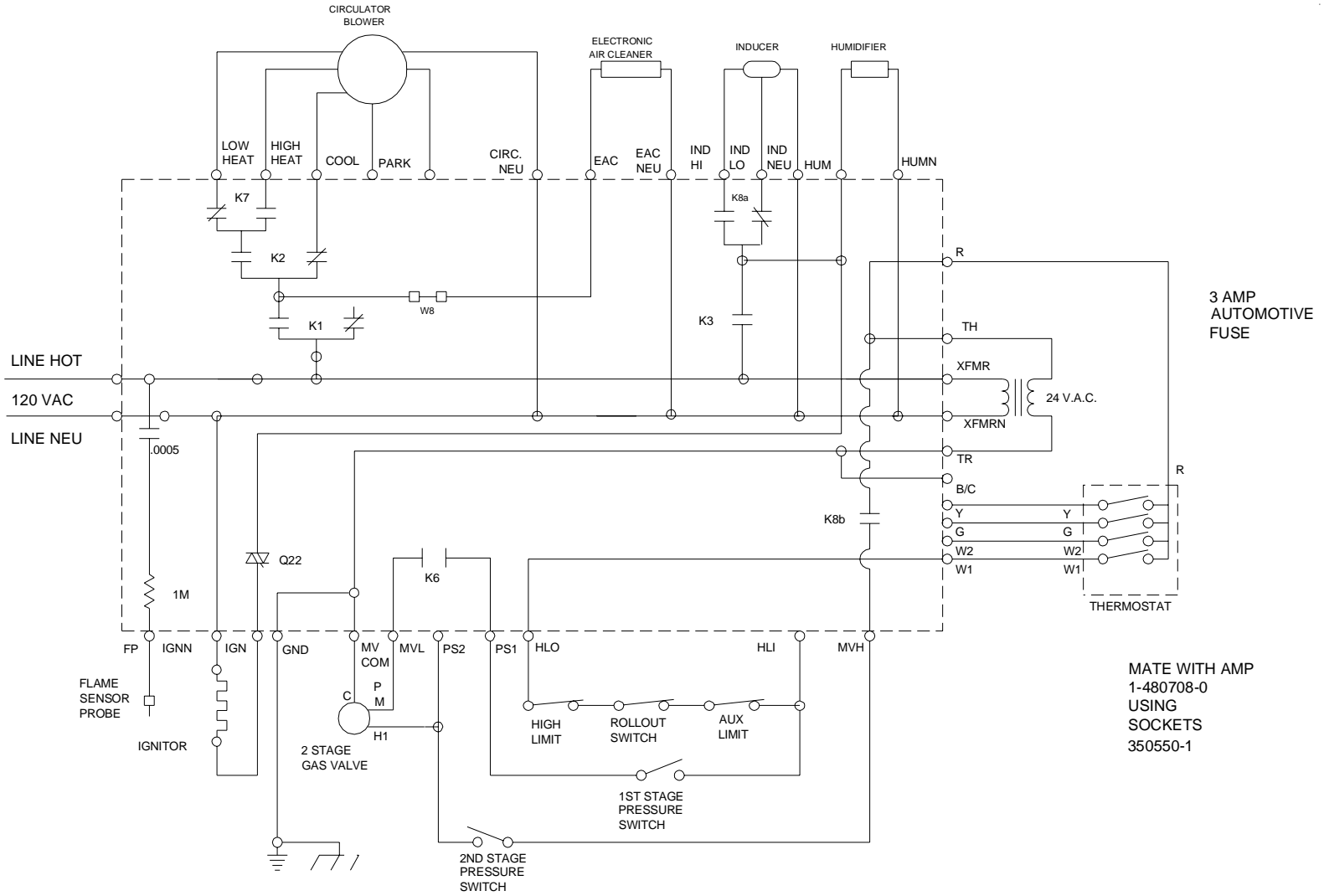

TO AVOID POSSIBLE ELECTRICAL SHOCK, PERSONAL INJURY,
OR DEATH, DISCONNECT THE POWER BEFORE SERVICING.

SCHEMATICS

TYPICAL SCHEMATIC
GMV9/GCV9 XA MODEL FURNACES
WR 50V61-289 INTEGRATED IGNITION CONTROL

This schematic is for reference only. Not all wiring is as shown above. Refer to the appropriate wiring diagram for the unit being serviced.

MATE WITH AMP
1-480708-0
USING
SOCKETS
350550-1